

THIS DOCUMENT CONTAINS PROPRIETARY INFORMATION AND EXCEPT WITH WRITTEN PERMISSION OF TRI-STAR ELECTRONICS INT'L, INC., SUCH INFORMATION SHALL NOT BE PUBLISHED, OR DISCLOSED TO OTHERS, OR USED FOR ANY PURPOSE, AND THE DOCUMENT SHALL NOT BE DUPLICATED IN WHOLE OR IN PART.

REVISIONS				
ZONE	LTR	DESCRIPTION	DATE	APPD
NC		NEW RELEASE PER E.O. 22125	5-3-13	[Signature]

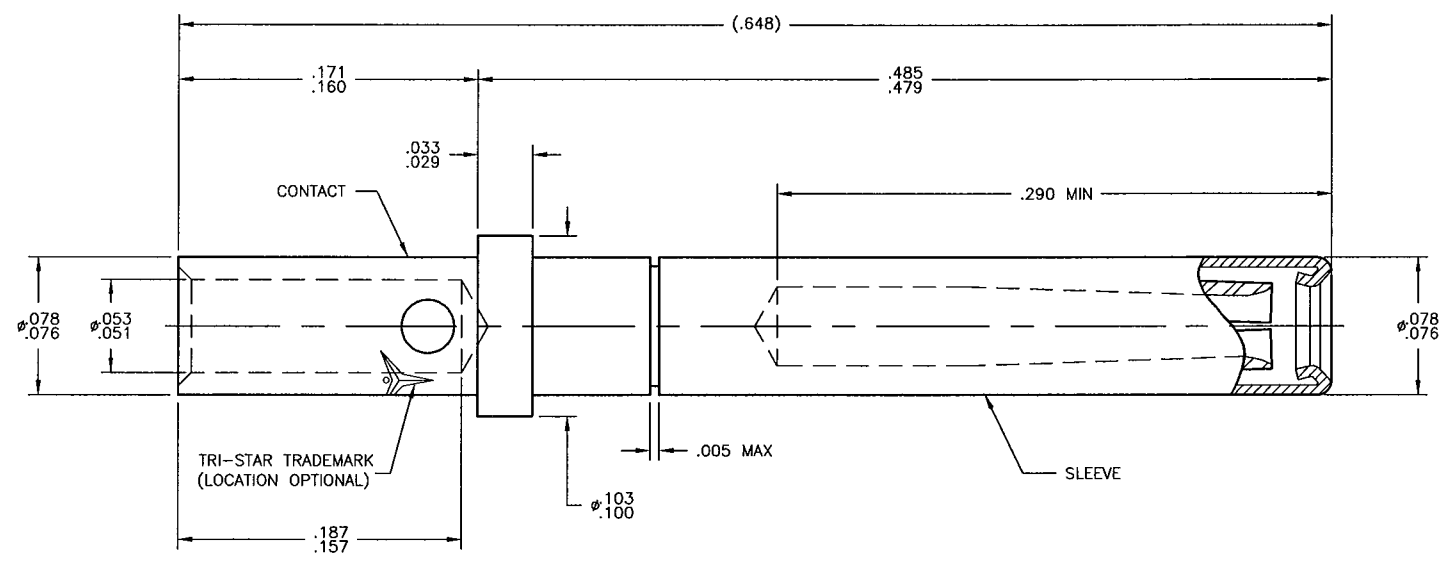

5. CRIMP TOOL DATA:
 BASIC CRIMP TOOL - M22520/1-01
 POSITIONER - M22520/1-02 RED
4. CONTACT ENGAGEMENT AND SEPARATION FORCES:
 ENGAGEMENT FORCE: 18.0 OZ MAX AND 12.0 OZ MAX AVG WITH A ϕ .041 DIA PIN.
 SEPARATION FORCE: .7 OZ MIN WITH A ϕ .039 DIA PIN.

3 FINISH: -CONTACT: NICKEL PLATE PER AMS-QQ-N-290.

2 MATERIAL. CONTACT: SUITABLE COPPER ALLOY PER AS39029.
 SLEEVE: STAINLESS STEEL, PASSIVATED

1. www.tri-starelectronics.com

NOTES: (UNLESS OTHERWISE SPECIFIED)

SALES DRAWING

APPLICATION	USED ON

QTY REQ'D	FSCM NO.	PART OR IDENTIFYING NO.	HOMOLOGATION OR DESCRIPTION	MATERIAL SPECIFICATION	ITEM NO.
PARTS LIST					
UNLESS OTHERWISE SPECIFIED DIMS. ARE IN INCHES; MILLIMETER EQUIV. ARE IN BRACKETS. TOLERANCES ARE:			CONTRACT NO.		
ANGLES .XX .XXX $\pm 30'$ $\pm .01$ [0.25] $\pm .005$ [0.127]			RATING:		
DO NOT SCALE DRAWING			APPROVALS		
MATERIAL: TREATMENT: FINISH:			DATE		
REF:			DRAWN: [Signature] 4-30-13		
			CHECKED: [Signature] 5-3-13		
			APPROVED: [Signature] 5-4-13		
			APPROVED: [Signature]		
			SCALE: NONE CAD NO: 10X-		

TRI-STAR ELECTRONICS INT'L, INC.
 2201 ROSECRANS AVENUE, EL SEGUNDO, CA 90245

CONTACT, ELECTRICAL CONNECTOR SOCKET, CRIMP REMOVABLE, #20

SIZE: **A** CAGE CODE: **55104** DWG NO.: C10-2018-A0988 REV: NC
 SHEET 1 OF 1