

REVISIONS				
ZONE	LTR	DESCRIPTION	DATE	APPD
	NC	NEW RELEASE PER E.O. 21068	7/11/11	LBO
	A	REVISED PER E.O. 21701	10/13/12	JL
	B	REVISED PER E.O. 22909	11-21-14	[Signature]

THIS DOCUMENT CONTAINS PROPRIETARY INFORMATION AND EXCEPT WITH WRITTEN PERMISSION OF TRI-STAR ELECTRONICS INT'L INC., SUCH INFORMATION SHALL NOT BE PUBLISHED, OR DISCLOSED TO OTHERS, OR USED FOR ANY PURPOSE, AND THE DOCUMENT SHALL NOT BE DUPLICATED IN WHOLE OR IN PART.

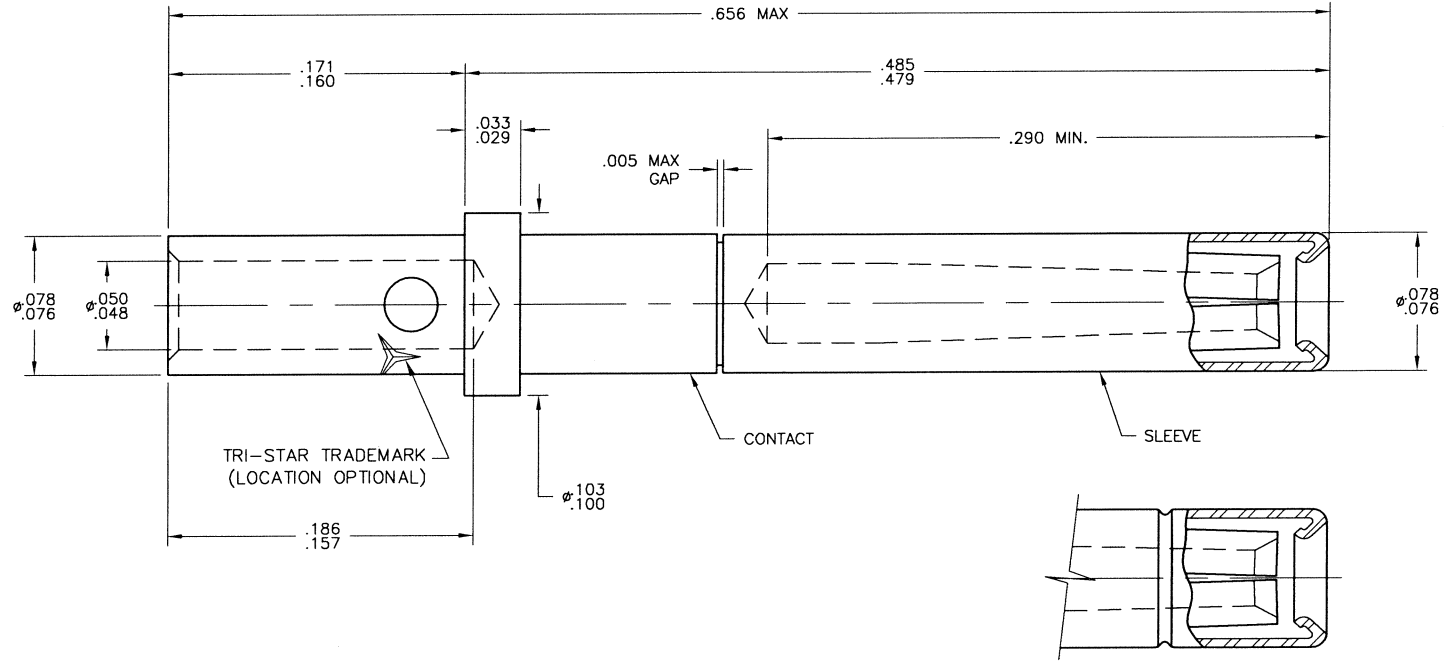

ALTERNATE SLEEVE CONFIGURATION

- CRIMP TOOL DATA:
BASIC CRIMP TOOL - M22520/1-01
POSITIONER - M22520/1-02 RED
- CONTACT ENGAGEMENT AND SEPARATION FORCES:
ENGAGEMENT FORCE: 18.0 OZ MAX AND 12.0 OZ MAX AVG WITH A ϕ .041 DIA PIN.
SEPARATION FORCE: .7 OZ MIN WITH A ϕ .039 DIA PIN.

3 FINISH: -CONTACT: GOLD PLATE PER MIL-DTL-45204 OVER NICKEL PLATE PER SAE-AMS-QQ-N-290

2 MATERIAL: CONTACT: SUITABLE COPPER ALLOY PER AS39029. SLEEVE: STAINLESS STEEL, PASSIVATED

1. www.carlisleit.com

NOTES: (UNLESS OTHERWISE SPECIFIED)

SALES DRAWING

QTY REQD	FROM NO.	PART OR IDENTIFYING NO.	NOMENCLATURE OR DESCRIPTION	MATERIAL SPECIFICATION	ITEM NO.										
PARTS LIST															
UNLESS OTHERWISE SPECIFIED DIMENSIONS ARE IN INCHES. TOLERANCES ARE:			CONTRACT NO.												
ANGLES .XX .XXX			RATING:												
1/30 ±.01			DRAWN: F.R. 7/8/11												
DO NOT SCALE DRAWING			CHECKED: H. LE 7/11/11												
MATERIAL:	TREATMENT:	FINISH:	APPROVED:	DATE:											
2		3	LBO	7/11/11											
REF:	APPROVED:	DATE:	SCALE:	CAD NO.:											
			NONE												
NEXT ASSEMBLY	USED ON	APPLICATION	<table border="1"> <tr> <td colspan="2"> </td> </tr> <tr> <td colspan="2"> CONTACT, ELECTRICAL CONNECTOR, SOCKET, CRIMP REMOVABLE, #2020 </td> </tr> <tr> <td>SIZE: A</td> <td>CAGE CODE: 55104</td> </tr> <tr> <td>DWG NO.: D10-2020-A0988</td> <td>REV: B</td> </tr> <tr> <td colspan="2">SHEET 1 OF 1</td> </tr> </table>					CONTACT, ELECTRICAL CONNECTOR, SOCKET, CRIMP REMOVABLE, #2020		SIZE: A	CAGE CODE: 55104	DWG NO.: D10-2020-A0988	REV: B	SHEET 1 OF 1	
CONTACT, ELECTRICAL CONNECTOR, SOCKET, CRIMP REMOVABLE, #2020															
SIZE: A	CAGE CODE: 55104														
DWG NO.: D10-2020-A0988	REV: B														
SHEET 1 OF 1															